

SPACE REQUEST

Please complete this form by including all requested information.

Submission of this form does NOT constitute a reservation.

You will be contacted by University Event Scheduling with confirmation. Incomplete requests will delay scheduling.

Host Department/Organization _____

Department/Organization Account Number _____

Authorized Contact Name _____

Phone _____ **Email** _____

Event Title _____

Event Type (Please Check One)

- Concert Meeting Lecture/Speaker Reception Info. Session/Workshop Banquet/Seated Meal

Event Date _____ **Event Start Time** _____ **Event End Time** _____ **Set-up Time** _____

Expected Attendance _____

Event Participants (Please check all that apply):

- Campus Community (Faculty, Staff or Students) General Public Paid Participants Invitation Only

Admission Fee? Yes No Amount _____

Catering or Food Service? None AU Catering Off-Campus Vendor* / Vendor Name _____
*(contract required)

Are you hosting a non-AU organization? Yes NO (Please note that rental fees may apply.)

If yes, please name the organization: _____

Please describe event in detail _____

Building/Space Preference

First Choice _____

Second Choice _____

Third Choice _____

Set-Up* (Examples provided on back of form)

- | | |
|--|------------------------------------|
| <input type="checkbox"/> Hollow Square | <input type="checkbox"/> Theater |
| <input type="checkbox"/> Reception | <input type="checkbox"/> Classroom |
| <input type="checkbox"/> Banquet | <input type="checkbox"/> U Shape |
| <input type="checkbox"/> Circle | <input type="checkbox"/> Other |

Audio Visual Requirements

- | | | |
|---|---|--|
| <input type="checkbox"/> VHS Player & Color Monitor | <input type="checkbox"/> DVD Player & Color Monitor | <input type="checkbox"/> VHS Player & Video Projector |
| <input type="checkbox"/> DVD Player & Video Projector | <input type="checkbox"/> Computer Data Projector | <input type="checkbox"/> Overhead Projector |
| <input type="checkbox"/> 35mm Slide Projector | <input type="checkbox"/> 16mm Film Projector | <input type="checkbox"/> Portable Projector Screen |
| <input type="checkbox"/> Audio Cassette Playback | <input type="checkbox"/> Audio CD Player | <input type="checkbox"/> VHS Video Camcorder with Tripod |
| <input type="checkbox"/> Audio CD Player | <input type="checkbox"/> Easels / number needed: ____ | <input type="checkbox"/> Directional Signage |
| <input type="checkbox"/> Podium | | |

Public Address System: Please indicate the number of items requested

____ Podium Mics ____ Table Mics ____ Stand Mics ____ Wireless Lav Mics
____ Handheld Wireless Mics ____ Mult Box (for press feeds)

Not all set-up configurations are suitable for all spaces. University Event Scheduling reserves the right to relocate your preferred request according to space availability and/or appropriateness. Some fees may apply based on space, services or equipment associated with the event.

Signatures

By signing below, I agree to abide by all University Center and campus regulations regarding the use of space and I agree to restore the space to an orderly condition for the next user. I also recognize that this is a request for space, not a confirmation & that I should not advertise this event until I have received a confirmation from University Event Scheduling.

Authorized Dept./Organization Rep. Date

Student Organization Advisor Date

Room Set-Up Styles

Please indicate set-up preference

*Please note that due to varying sizes, some set-up styles may not be suitable for certain MGC or Butler Pavilion rooms. Room capacity may also change depending upon set-up style and special needs.

Classroom Style

* NOT recommended for MGC 244 or Butler Conference

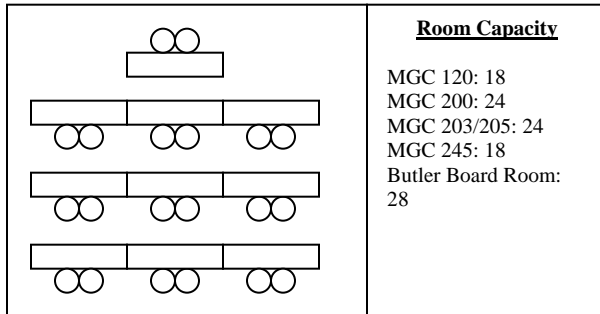

Theater Style

* NOT recommended for MGC 244 or Butler Conference

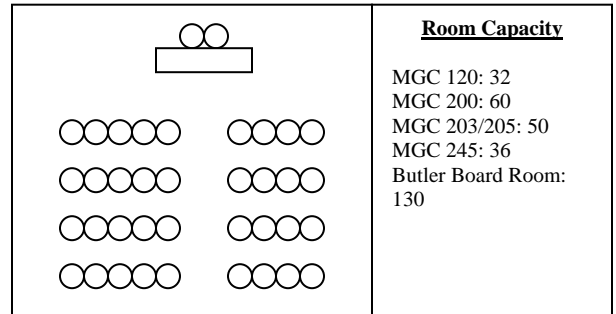

Hollow Square

* Additional seating may be requested

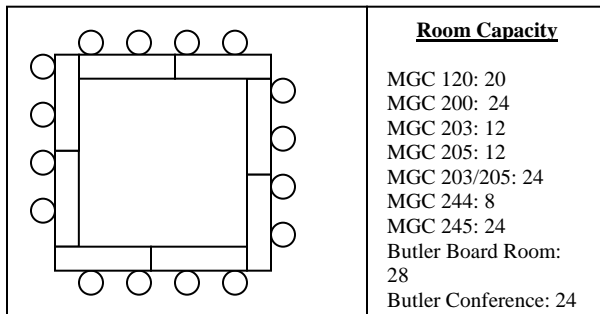

U-Shape

* NOT recommended for MGC 244

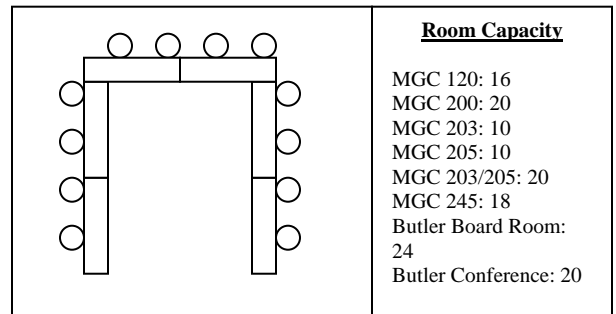

Banquet

* NOT recommended for MGC 203, 205, 244, or Butler Conference

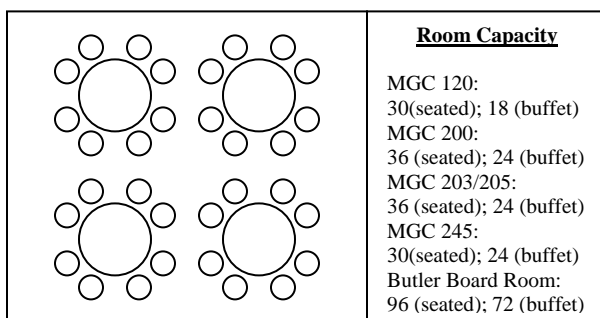

Reception

*NOT recommended for MGC 203, 205, 244, or Butler Conference

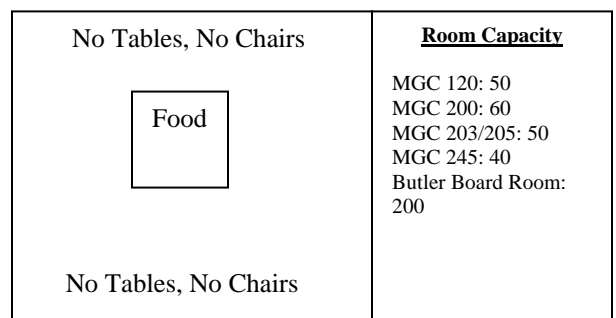

Circle

* NOT recommended for MGC 244 or Butler Conference

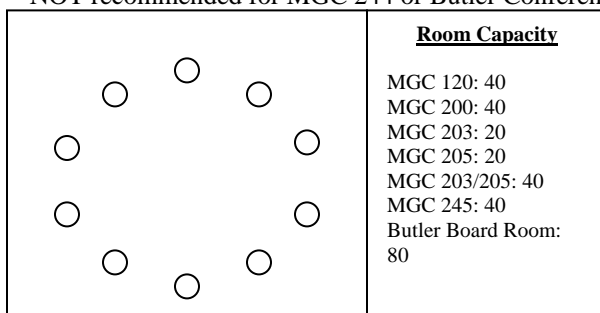

Other (Please indicate set-up style in space provided and/or placement of AV/podium/etc.):